



Gas



Liquid & Slurry



Solid & Powder



Steam & Water

SENTRY SPIRAL TUBE Heat Exchangers

SAMPLE CONDITIONING

A spiral tube heat exchanger is a coil assembly fitted in a compact shell that optimizes heat transfer efficiency and space. Every Sentry® spiral assembly has welded tube to manifold joints for durability and strength. The coil assembly is welded to a head and fitted in a compact shell. The spaces or gaps between the coils of the spiral tube bundle become the shell side flow path.

Typical applications include:

- Pump seal coolers
- Sample coolers
- Inter/after coolers
- Acid heaters/coolers
- Instant hot water heaters
- Process condensers

MODELS

Varied

BENEFITS

The spiral shape of the flow for the tubeside and shellside fluids creates centrifugal force and secondary circulating flow that enhances the heat transfer on both sides in a true counterflow arrangement. Since there are a variety of multiple parallel tube configurations (diameter, number and length), efficiency is not compromised by limited shell diameter sizes as it can be with shell and tube designs.

The profile of a spiral is compact and fits in a smaller footprint than a shell and tube design. Since the tube bundle is coiled, space requirements for tube bundle removal are significantly reduced.

When exotic material is required, a spiral tube heat exchanger minimizes the material used since manifolds replace the channels, heads and tubesheets of a conventional shell and tube design. The shell side is usually smaller than a comparable shell and tube design and there are no requirements for tube supports or pass dividers.

FEATURES

- Flow rates to 100 GPM (378 LPM)
- Sample conditions up to 5000 psi (345 bar) and up to 1000° F (540° C)
- Optimal design for corrosive fluid/gases
- Vapor condensing/gas stripping capabilities
- High flow in a small footprint
- Highly resistant to thermal and hydraulic shock
- Bolted or all welded shell
- Numerous flow path and connection configurations
- Compact and lightweight; easy to install



Sample. Monitor. Measure.

SENTRY

Any Application. Anywhere.

CROSS SECTION OF A SPIRAL TUBE HEAT EXCHANGER

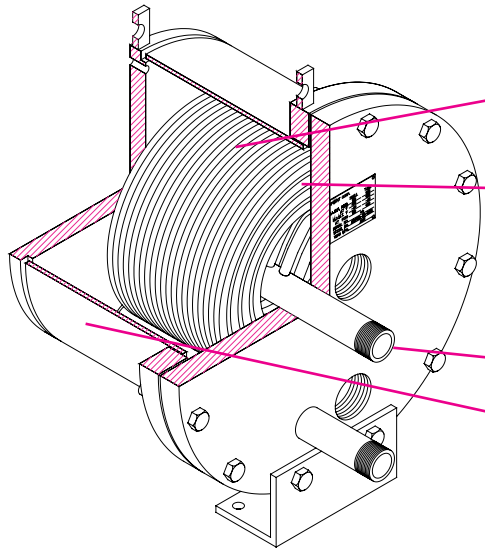

OPTIMIZED PERFORMANCE

Multiple tube side parameters (diameter, length, number and material)

Variable shellside flow path gap and length

EASY TO INSTALL

Simple piping and access

Easy to remove shell for inspection, cleaning or replacement of tube bundle – virtually no tube bundle pull requirement

SPECIFICATIONS

	shell design	tube design
materials	carbon steel and stainless steel	stainless steel, Hastelloy, Inconel and other alloys
standard pressure rating	150 psig at 400°F (10.3 barg at 204°C)	up to 5000 psig at 1000°F (up to 345 barg at 540°C)
construction	bolted or welded with NPT, FLG, SW or BW connections	welded tube to manifold joints with NPT, FLG, SW or BW connections
surface area	1 to 177 ft. ² (0.1 to 16 m. ²)	

ASME code stamp available upon request

sentry-equip.com

966 Blue Ribbon Circle North, Oconomowoc, WI 53066 U.S.A. | +1-262-567-7256 | sales@sentry-equip.com

© 2015 Sentry Equipment Corp. All rights reserved. All product and company names are property of their respective owners. It is solely the responsibility of end users, through their own testing and analysis, to select products and materials suitable for their specific application requirements, ensure they are properly installed, safely applied and properly maintained, and to limit their use to their intended purpose. Improper selection, installation or use may result in personal injury or property damage.

S-SC&HE-SPS-00127-11 3-16



COMPANY WITH
QUALITY SYSTEM
CERTIFIED BY DNV GL
= ISO 9001 =